

Simple Operation, Stable Performance

Operación Sencilla, Rendimiento Estable / Operação Simples, Rendimento Estável

VERTICAL MAIZE DEGERMER

DESGERMINADORA VERTICAL DE MAÍZ

DEGEMINADOR VERTICAL DE MILHO

VBF5AM-L / VBF10AM-L



TKN1000



TEPMIX



VBF5AM-L

VBF10AM-L

Features / Características

1. Capacity / Capacidade / Capacidade

According to production scale. VBF5AM-L for small, VBF10AM-L for medium / large production scale.

De acuerdo con escala de producción. VBF5AM-L para pequeña, VBF10AM-L para mediana / alta escala de producción.

De acordo com a escala de produção. VBF5AM-L para pequena, VBF10AM-L para média / alta escala de produção.

2. Yield / Rendimiento / Rendimento

High yield and the best option for large flaking grits production.

Rendimiento alto y la mejor opción para producción de grits.

Alto rendimento e a melhor opção para produção de grãos.

3. Accessories / Accesorios / Acessórios

SATAKE offers screwconditioner TEMPMIX and tempering tank TNK1000. Both equipments attend 4 to 5t/h production capacity. (Not included in VBF degermer's price).

SATAKE ofrecería sinfin humectador TEMPMIX y tolva de descanso TNK1000. Ambos equipos atienden 4 a 5 t/h de capacidad de producción (No incluidos en el precio de desgerminadora VBF).

SATAKE oferecia rosca umidificadora TEMPMIX e tanque de descanso TNK1000. Os dois atendem 4 a 5 t/h de capacidade de produção (Não são inclusos no preço de degerminador VBF).

* Specifications subject to change without previous notice.

* Especificaciones pueden ser cambiadas sin información previa.

* As especificações estão sujeitas a alterações sem aviso prévio.

*) Input material moisture contents recommendation :

12 ~ 13.5% (B.U.)

*) Recomendación para la humedad del material de entrada:

12 ~ 13.5% (B.U.)

*) Recomendação para a umidade do material de entrada:

12 ~ 13,5% (B.U)

VERTICAL MAIZE DEGERMER DERGEMINADORA VERTICAL DE MÁIZ DEGERMINADOR VERTICAL DE MILHO

Specification / Especificación / Especificação

Model / Modelo :	VBF5AM-L	VBF10AM-L	TEMPMIX	TNK1000
Input Capacity (t/h) : *1) Capacidade de entrada (t/h) : *1) Capacidad de entrada (t/h) : *1)	2 ~ 3	4 ~ 5	~ 5	~ 0,8
Material :	Milho / Maize / Maiz			
Power Requirement : Energia (Kw):	37 / 6P 1,5 / 4P 1,5 / 2P	55 / 6P 1,5 / 4P 2,2 / 2P	2,2 / 4P	--
Suction Air Volume (m ³ /min) : Volume sucção de ar (m ³ /min) : Volumen succion de aire (m ³ /min) :	35	45	--	--
Suction Air Pressure (kpa) : Pressão de sucção de ar (kpa) : Pression de succion de aire (kpa) :	1 ~ 1,5	1 ~ 1,5	--	--
Gross Weight is no included in motors (kg) : Peso bruto sem motor (kg) : Peso bruto sin motor (kg) :	900	1200	200	140

*1) Input Capacity may vary depend on the condition of the material to be processed.
Any other detailed information, please ask SATAKE.

*1) Capacidade de entrada pode variar conforme a condição do material a ser beneficiado.
Para outras informações, favor comunicar-se com a SATAKE.

*1) Capacidad de entrada puede variar de acuerdo a la condición del material a ser procesado.
Para otras informaciones favor comunicarse con SATAKE.

Dimensions / Dimensiones / Dimensões

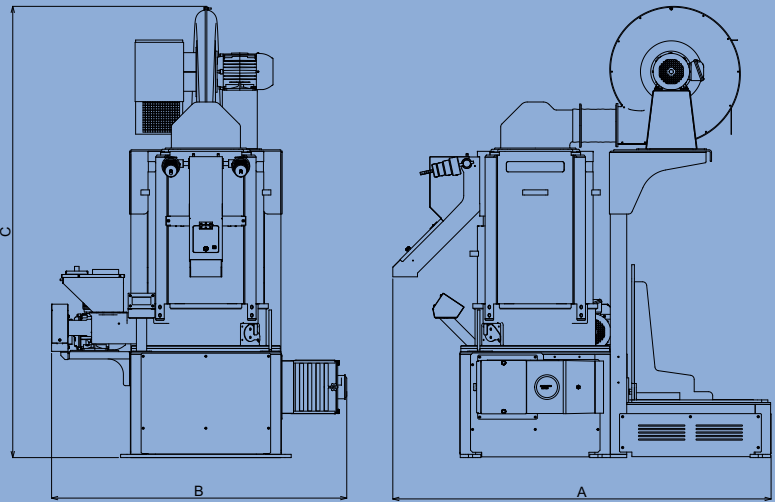

	A	B	C
VBF5AM-L	1650	1400	1880
VBF10AM-L	1840	1440	2200

All Satake products are the subject of continuous development and, as a result, their specification may change and detail from those shown.

Todos os produtos da Satake estão sujeitos a desenvolvimentos contínuos e, como resultado, suas especificações podem mudar e diferir em detalhes dos que mostramos.

Todos los productos Satake están en desarrollo continuo y puede resultar diferencias en las especificaciones y detalles indicados en ese catálogo.

SATAKE CORPORATION

Head Office
2-30 Saijo Nishihonmachi,
Higashi-Hiroshima-shi
Tel: +81-82-420-8560/8539
Fax: +81-82-420-0865
URL: www.satake-japan.co.jp

SATAKE USA INC.
10900 Cash Road,
Stafford, Texas, 77477,
U.S.A
Tel: +1-281-276-3600
Fax: +1-281-494-1460
URL: www.satake-usa.com

SATAKE (CANADA) INC.
5100 Fallingbrook Drive,
Mississauga, Ontario, L5v 1S7,
Canada
Tel: +1-905-858-0791
Fax: +1-905-858-0957
e-mail:salex@satake-

SATAKE AMERICA LATINA LTDA
Rua Xavantes, 155-Pav.20,
Bairro Atiradores, CEP
89203-210, Joinville, Santa
Catarina, Brasil
Tel: +55-47-3461-1313
Fax: +55-47-3461-1300
URL: www.satake.com.br

SATAKE EUROPE LTD.
PO. Box 53, Horsfield Way,
Bredbury Industrial Park,
Breadbury,
Stockport, Cheshire, Sk6 2SU, U.K.
Tel: +44-161-406-3800
Fax: +44-161-406-3801
URL:www.satake-europe.com

SATAKE CORPORATION has obtained ISO 9001 and ISO 14001 certification.

These international standards for management systems ensure Satake will continue to provide high quality products and services.

ISO 9001 Certification
(Quality Management Systems)

ISO 14001 Certification
(Environmental Management Systems)

SATAKE INDIA ENGINEERING PVT.
LTD.
4th Floor, Tower-1, HB Twin
Towers,
A2, 3, 4, Netaji Subhash Place,
Wazirpur District Centre, New
Delhi, 110034, India
Tel: +91-11-4706-2626
Fax: +91-11-4706-2624

SATAKE (THAILAND) CO., LTD
133.134 Moo 5, Bangkok,
Mueang
Pathum Thani, Pathum Thani
12000, Thailand
Tel: +66-2-501-1180
Fax: +66-2-501-1188
URL: www.satake.com:8080

SATAKE INTERNACIONAL BANGKOK
CO. LTD.
888/84 Mahatun Plaza Bld., 8 th
Floor, Ploenchit Rd. Lumpini,
Pathumwan, Bangkok, 10330,
Thailand
Tel: +66-2-651-5845
Fax: +66-2-651-5848
URL: www.satake.com:8080

SATAKE MANUFACTURING (SUZHOU)
CO. LTD.
229 Jin Feng Road, Suzhou New
District, Suzhou, Jiangsu Province,
215129, China
Tel: +86-512-6536-8225
Fax: +86-512-6336-5922
URL: www.satake.cn

SATAKE AUSTRALIA PTY. LTD.
15 Leland Street, Perrith, N.S.W.,
2750, Australia
Tel: +61-2-4725-2600
Fax: +61-2-4725-2601
URL: www.satake.com.au